

DC330MINI

Smart Compact Converting



SPECIFICATIONS	METRIC	IMPERIAL
Web width	50 - 330 mm	2 - 13"
Substrate thickness	50 - 200 µm	2 - 8 pt.
Die Station		
Semi-rotary speed	65 m/min	213 ft/min
Full-rotary speed	72 m/min	236 ft/min
Die plate size	50 - 558,8 mm	2 - 22"
Unwinder		
Diameter max.	700 mm	27.6"
Core diameter	76,2 or 152,4mm	3" or 6"
Rewinder		
Diameter max.	500 mm	19.7"
Standard core diameter	76,2 mm	3"
Waste matrix rewinder diameter	up to 800 mm on request	up to 31.5" on request
Flexo Station		
Print cylinder size	228 - 482,5 mm	9 - 19"
Spot varnish option with digital sensor register control and slow run		
Slitting Station		
Knife type	Pneumatic crush, SmartCrush, shear or razor	
Minimum distance crush	12,7 mm	0.5"
Minimum distance shear	10 mm	0.4"
Dimensions (WxDxH)	2,7 x 1,5 x 2,0 m	8.8 x 5.0 x 6.5 ft

- *The fastest small footprint machine in the market - "Swiss Army knife" converter*
- *Works inline with any digital press*
- *Works inline with GM Hotfoil/Screen embellishment units*
- *Upgrade to double varnish and turret*
- *Train an operator in a day*
- *Online support and remote diagnostics*
- *Industry 4.0 ready*

This latest generation of the digital label finishing machine has been redesigned and features new electronics, a newly-designed control panel and an updated user interface. Based on the DC330 platform designed and improved over 8 generations – the **DC330MINI** has a strong and extremely proven background.

All-in-one compact solution

Like the previous generation, it maintains the same best small footprint to minimize waste and maximize productivity. DC330MINI provides UV flexo varnish, lamination, super-gloss, cold-foil, die cutting and slit and rewind on one single compact platform.

The drive train in the DC330 series of machines is completely servo driven offering low maintenance servo-driven tension control and good registration. Minimum waste die dials in within one rotation. No station movement or mechanical setup needed and lastly graphical touch screen which shows the machine configuration, spindle directions and web-up.

Online Support - easy web access and maintenance

- Remote support and diagnostics using machine data
- Cloud statistics – operator login, productivity
- Insert a new module in hours, not days

Smart converting machine

- Industry leading user interface
- Precision cutting to reduce waste
- Best footprint and shortest web path
- Minimum waste
- High performance - up to 72m/min
- Inline options for any digital press
- TRESU close chamber varnish option for high speed applications
- Easy to use and learn

DC330 MINI

Features and options



The **UV Flexo** varnish station with optional registration allows the higher level of embellishment with spot and Super Gloss varnish.

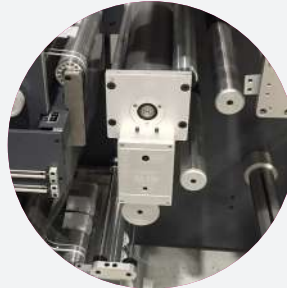

GM SmartChill - a new chilling solution that eliminates curling and melting issues when UV curing thin foil substrates. Maximises the variety of substrates applicable.



GM SmartCrush - An ultra-quick set knives system, allowing fast and precise setting of each crush knife - also while running.



GM Buffer - easy switching between inline and offline mode. It synchronizes the speed between digital press and finisher, and allows operator time to change the roll.



Runs inline with GM Hotfoil/Screen embellishment units

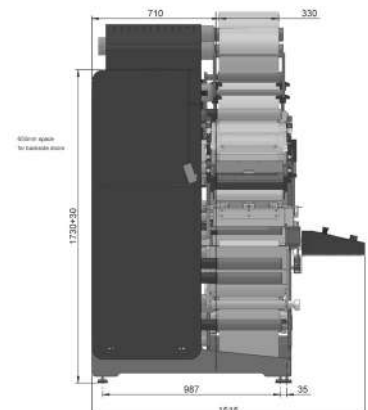
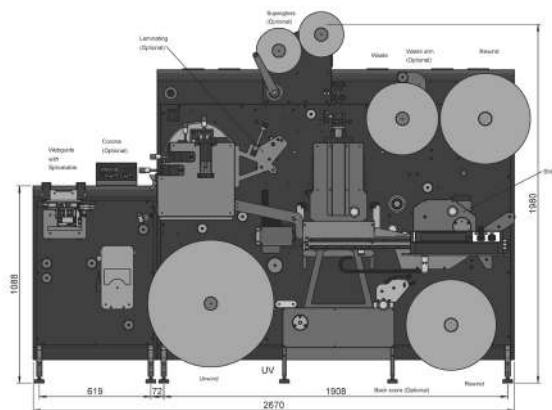

GRAFISK MASKINFABRIK A/S
Klintehøj Vænge 12, 3460 Birkerød
Phone: +45 4581 2300

Email: gm@gm.dk
Web: www.gm.dk



Konica Minolta Business Solutions
New Zealand Limited

Free Call 0800 475 005
konicaminolta.co.nz/home