

# Onyx Pro

The Onyx Pro features our unique continuous fiber reinforcement at an affordable price. Built on a durable chassis with precision components, the Onyx Pro prints fiberglass-reinforced thermoplastic parts that are 10x as strong as traditional printing plastics.

<b>Printer Properties</b>	<b>Process</b>	Fused filament fabrication, Continuous Filament Fabrication
	<b>Build Volume</b>	320 x 132 x 154 mm (12.6 x 5.2 x 6 in)
	<b>Weight</b>	16 kg (35 lbs)
	<b>Machine Footprint</b>	584 x 330 x 355 mm (23 x 13 x 14 in)
	<b>Print Bed</b>	Kinematic coupling — flat to within 160 µm
	<b>Extrusion System</b>	Second-generation extruder, out-of-plastic detection
	<b>Power</b>	100–240 VAC, 150 W (2 A peak)
<b>Materials</b>	<b>Plastics Available</b>	Onyx
	<b>Fibers Available</b>	Fiberglass
	<b>Tensile Strength</b>	590 MPa (19.0x ABS, 16.4x Onyx) *
	<b>Flex Modulus</b>	22 GPa (10.7x ABS, 6.1x Onyx) *
<b>Part Properties</b>	<b>Layer Height</b>	100 µm default, 200 µm maximum
	<b>Infill</b>	Closed cell infill: multiple geometries available
<b>Software</b>	<b>Supplied Software</b>	Eiger Cloud (Other options available at cost)
	<b>Security</b>	Two-factor authentication, org admin access, single sign-on

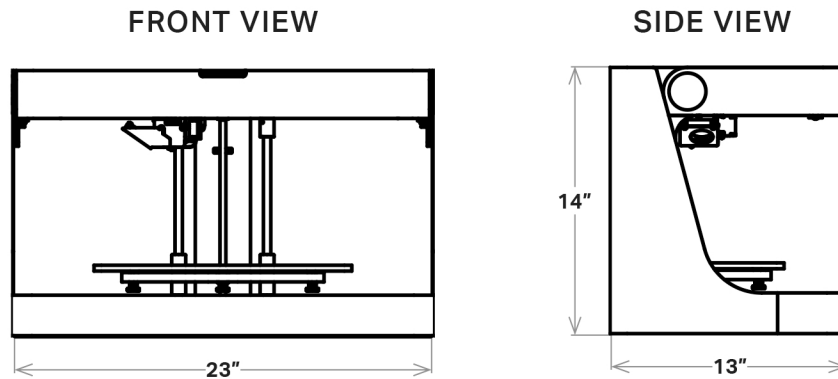

\* Continuous fiberglass data. **Note:** All specifications are approximate and subject to change without notice.