

Mark Two

Replace machined aluminum tooling—jigs, jaws, and fixtures—with stronger parts for a fraction of the price. The Mark Two combines our unique continuous carbon fiber reinforcement with workhorse reliability for versatile parts with 26x the strength of ABS, ready same-day for use straight off the printer.

Printer Properties	Process	Fused filament fabrication, Continuous Filament Fabrication
	Build Volume	320 x 132 x 154 mm (12.6 x 5.2 x 6 in)
	Weight	16 kg (35 lbs)
	Machine Footprint	584 x 330 x 355 mm (23 x 13 x 14 in)
	Print Bed	Kinematic coupling — flat to within 160 µm
	Extrusion System	Second-generation extruder, out-of-plastic detection
	Power	100–240 VAC, 150 W (2 A peak)
	Materials	Plastics Available
Fibers Available		Carbon fiber, fiberglass, Kevlar®, HST fiberglass
Tensile Strength		800 MPa (25.8x ABS, 22.2x Onyx) *
Flex Modulus		51 GPa (24.8x ABS, 14.2x Onyx) *
Part Properties	Layer Height	100 µm default, 200 µm maximum
	Infill	Closed cell infill: multiple geometries available
Software	Supplied Software	Eiger Cloud (Other options available at cost)
	Security	Two-factor authentication, org admin access, single sign-on

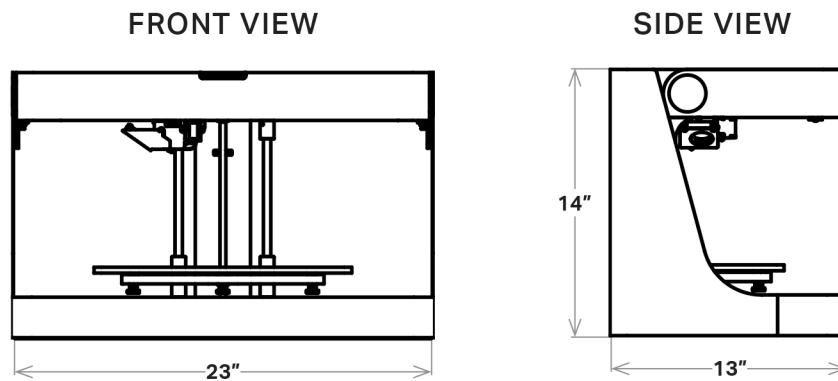

* Continuous carbon fiber data. **Note:** All specifications are approximate and subject to change without notice.