

Onyx One

Built on the same platform as our award-winning Mark Two, the Onyx One is designed from the ground up for quality and reliability in a form factor that fits on your desktop. Onyx parts are twice as strong as conventional printing plastics.

Printer Properties	Process	Fused filament fabrication
	Build Volume	320 x 132 x 154 mm (12.6 x 5.2 x 6 in)
	Weight	15 kg (34 lbs)
	Machine Footprint	584 x 330 x 355 mm (23 x 13 x 14 in)
	Print Bed	Kinematic coupling — flat to within 160 µm
	Extrusion System	Second-generation extruder, out-of-plastic detection
	Power	100–240 VAC, 150 W (2 A peak)
Materials	Plastics Available	Onyx
	Fibers Available	None
	Tensile Strength	36 MPa (1.2x ABS) *
	Flex Modulus	3.6 GPa (1.7x ABS) *
Part Properties	Layer Height	100 µm default, 200 µm maximum
	Infill	Closed cell infill: multiple geometries available
Software	Supplied Software	Eiger Cloud (Other options available at cost)
	Security	Two-factor authentication, org admin access, single sign-on

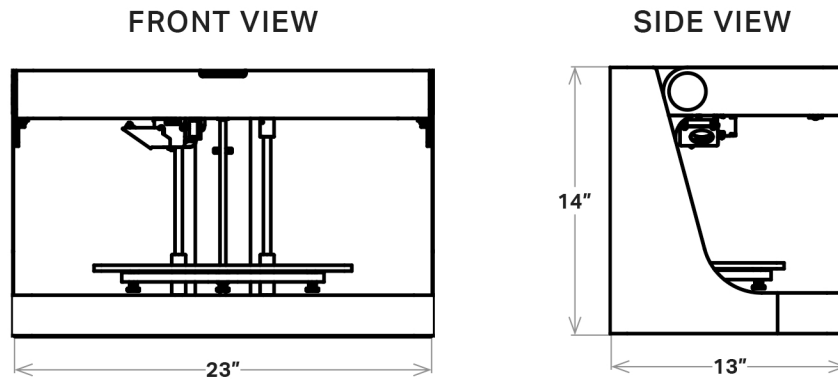

* Onyx data. **Note:** All specifications are approximate and subject to change without notice.